

gram since the early days of the Shuttle Program. The contents of the program are constantly being updated to assure timely and complete data to support all levels of the program at all affected NASA Centers and contractors. Some of the requirements documents that apply directly to this work are:

Level I (NASA Headquarters), NHB8060.1A, "Flammability, Odor, and Offgassing Requirements and Test Procedures for Materials in Environments that Support Combustion." This is also applicable to those payloads that are placed in the Orbiter habitable areas.

Level II (JSC) SE-R-0006A, "NASA-JSC Requirements For Materials and Processes."

Level III (MSFC) MSFC-STD-506 "MSFC-NASA Standard Materials and Process Control."

Level III (KSC) - Document is not known by the Panel.

Rockwell International, SD72-SH-0172, "Space Shuttle Orbiter Materials Control and Verification Plan."

Rockwell International, MC999-0096D, "Materials and Processes Control and Verification System for Space Shuttle Program."

The Panel has reviewed some of the MATCO program and it will continue to review this area to assure that the methods for implementation are adequate to the program needs. In using MATCO information to evaluate materials actually used on the Shuttle, the program must have

an effective configuration control system to assure that the materials evaluated in the design phase or in fact used on the flight vehicle and any materials subsequently introduced into the program are also carefully evaluated. Thus the periodic configuration control board activities examine the materials problem for every change made to the hardware and design reviews.

As part of NASA's continuing effort to establish uniform and complete policy and responsibilities on areas that affect safety and mission success Headquarter's has issued a Management Instruction on NMI 1710.3, dated April 8, 1976, "Design, Inspection, and Certification of Pressure Vessels and Pressurized Systems."

Attachment 6-2 is a letter covering the potential problems associated with nuclear detonations. It is indicative of some of the areas of safety examined by the Panel to assure program attention to as many details as possible.

Much of the material that follows is also a part of the work done in the safety, reliability and quality assurance efforts discussed above. However, it is discussed separately because of the Panel's interests.

6.3.3.3 Flight Termination System

The Flight and Ground System Specification (Volume X of JSC 07700) was revised April 12, 1976 (Change No. 30) so that the requirements for

range safety now reads as follows:

"The Flight Termination System shall comply with the range safety Flight Termination System requirements of AFETRM 127-1 and SAMTECM 127-1. The flight vehicle shall comply with the range safety requirements of SAMTECM 127.1. In those instances where adherence is judged to be inappropriate from either an operational or technical standpoint, such instances shall be brought to the attention of the DOD/NASA for resolution."

This guidance is developed in greater detail for those sections of the document that deal with the specifics of mission abort operations functions, flight system design on the SRB and ET including destruct safing. The current effort is to baseline mutually acceptable concept for NASA/DOD Space Shuttle Range Safety and define the mode of resolution for problems that subsequently develop. The current hardware safety system is called a "Triplex" system in that each SRB and the ET have destruct systems on-board. There is sufficient redundancy to assure proper operation in either the armed mode or the safe mode. Items of interest that will be examined by the Panel in the near future include the following: the agreed-to baseline concept; current open problems regarding the design, installation, and utilization of such a system; any schedule and procurement constraints; current design options and their advantages and disadvantages; and

constraints on operational and DDT&E missions.

6.3.3.4 SRB Fracture Control Board

Recognizing the importance of fracture control of SRB reusable components, MSFC established an SRB Fracture Control Board which held its first formal meeting on October 8, 1975. The Board is set up as shown in Figure 6-2. This board has undertaken a number of concurrent activities to assure both that every aspect of fracture control for the SRB is properly accounted for and not information resulting from this effort is furnished to other Shuttle activities for their use. Each of the major contractors on the SRB have developed fracture control plans which are either being implemented or in process of being implemented at this time. These plans provide for the following functions:

- a. Development of fracture control technical guidelines and directions.

- b. Establishment of a contractor Fracture Control Board. The Board reviews and approves all fracture analyses, fracture control test data, and component control plans. Finally it monitors compliance, and establishes necessary corrective actions and reports. It reports to the NASA SRB Fracture Control Board and is also a major support for the Material Review Board.

The MSFC board, in addition to working with the contractor units,

does its own independent analysis and testing and maintains a detailed list of "technical concerns and action items" and assures their resolution.

6.3.3.5 Abort Planning for Shuttle Flights

Based on the material provided to the Panel during its reviews of the abort area some concerns have surfaced. These are in regard to the timeliness and depth of studies to define abort capabilities, and supporting the assessment of aggregate risk for any given mission. The Level I, II and III documentation sets forth requirements in the general area of aborts as well as specifics relating to intact abort, contingency aborts, and appropriate loss of critical functions. Such abort analyses are directed primarily at the DDT&E and operational orbital missions, although such analyses apply to the ALT missions as well. Abort planning and activities associated with ALT are covered in Section 8, "Flight Test Program."

In addition to the many efforts going on at both NASA Centers and the contractors a number of Level II panels and review teams have been examining this area in some detail. Some of these are the Crew Safety Panel, the Systems Integration Review Teams, Flight Operations Pane, SR&QA Panel, Ascent Flight Systems Integration Group, and the Abort Panel.

The Level II specifications have specified the requirements for

intact abort and the intact abort modes. These same specifications have specified the requirements for contingency abort and the contingency abort criteria. However, the contingency abort modes have as yet not been defined. Attachment 6-1 is the Shuttle Program Office response to the Panel's previous Annual Report covering this particular area of concern. An area of concern to the Panel has been the abort capability during the early stages of ascent when the Solid Rocket Motors and the Orbiter Main Engines are all burning.

The Level I requirement (JSC 07700, Volume X) is that potential failures in a system that could cause loss of critical functions will be eliminated by including appropriate safety margins or redundancy levels in the design. In addition crew ejection seats will be provided for the initial series of Shuttle OFT launches until the flight worthiness of the launch system has been demonstrated. These ejection seats as baselined for the orbital flight test program provide crew escape capability up to approximately 80,000 feet. The SRB thrust termination capability and the use of abort rockets were included in the early Shuttle baseline. However, they have been deleted by Level II action. The PCIN S00015 deleting the abort solid rocket motors was approved in 1972. The PCIN S00040 eliminated SRB thrust termination in 1973.

6.3.4. Special Topics

6.3.4.1 Lessons Learned

The Panel reviewed the management system to assure the appropriate application of lessons learned from prior programs.

The task team met with personnel at every level of JSC, KSC, MSFC, Rockwell, and Rocketdyne. They were supported by the efforts of the others who also focused on the application of lessons in areas under their review. The Panel as a whole then discussed the system as they found it with Shuttle management.

Assurance that lessons are in fact being implemented is accomplished through:

- a. Lessons are incorporated into such documents as design manuals, process specifications, etc.
- b. SR&QA conduct audits to assure lessons are being implemented where proper to do so.
- c. Contractors' reports on their implementation of lessons at quarterly reviews and other in-house meetings.
- d. The Aerospace Safety Advisory Panel reviews this area on a periodic basis at various NASA and contractor sites.

The Panel is also interested in assuring that lessons learned on the current Shuttle program are examined and applied as appropriate here and now. Here is an example of how experience is captured, passed on, and finally utilized. This comes from the External Tank

data reviewed and discussed at MSFC in early Fall 1975. The Martin-Marietta team working with JSC reported, at that time, the data as presented on Table 6-2. In addition to the many NASA documents they found 67 other lessons from MMC and Airforce documents as well. Based on the material discussed at that time the MSFC area showed the following brief statistics:

<u>Element</u>	<u>Total Number of Lessons Applicable</u>	<u>Applying Directly</u>	<u>Meeting the Intent</u>
External Tank	546	520	26
SSME	160	148	12
Solid Rocket Booster	81	80	1

6.3.4.2 Wire Usage and Implementation on Shuttle Elements

As the result of his Apollo experience the Deputy Administrator requested the Panel to review the use of 26 AWG wire and the use of teflon on Shuttle.

The lesson learned is cited in NAA Technical Note, D-7598, dated March 1974, "Apollo Experience Report - Development Flight Instrumentation."

"In LM-1, the scarcity of available space and the consequent miniaturization of certain DFI components led to the design of a central signal-conditioning unit that had a density of 1600 connector pins over a 45-square-inch faceplate. and the mating cable

harness consisted primarily of No. 26 AWG wire. After a series of requirements changes and trouble-shooting procedures that involved moving and opening the signal conditioning unit, some of the wires in the harness became fatigued and broken. This problem was also manifested in the harness in other areas where cable movement was excessive. The situation deteriorated to the point at which attempts to rectify certain cable breakages precipitated further breakages in adjacent areas. From the cabling problems cited, three conclusions can be drawn. First, high-density wiring configuration should be avoided. Second, signal conditioning should be decentralized or made remote so that low-density connector configuration can be achieved to permit easy access and repair and result in inflexible bundles of cables. Third, the DFI system involved frequent equipment changes; therefore, it should use a heavier gauge wire than the more permanently sited, operational-type equipment."

Based on data received to date the use of this gauging on Shuttle in wiring and connections is controlled as follows:

- a. Of the approximately 910,000 feet of wire in the Orbiter, most of it consists of 22-AWG and 24-AWG. For DFI, signal wiring the Orbiter 101 contains about 30,000 feet of the new 26-AWG and Orbiter 102 about 70,000 feet of it.
- b. The 26AWG, when used on Shuttle elements, is made of

an alloy of copper having a considerably higher tensile strength than the copper wire referred to in the above Apollo usage. Thus the new 26-gauge wire is closer in strength to the old 24-gauge wire. In general the 24 and 26 gauge wire is now stranded nickel coated high-strength copper alloy. For 22-AWG and larger the conductor is copper as before.

c. Wherever possible high-density wire configurations are being avoided. Signal-conditioning is decentralized in a manner which supports the use of low-density connector configurations so as to permit easy access and reduced chance of wire fatiguing or bending.

d. Pin-socket connectors have posed many problems in the past due to the need for near-perfect alignment, proper final seating, and the correct electrical circuitry between the lines to the pin and socket. A somewhat different design is being used by the MSFC elements in that the fixed-portion of the connector now has the pins and the mating portion is the socket. This appears to provide for easier installation and better mating of the connectors.

e. Certain sensing devices, such as strain gauges, use pig-tails of wire in a gauge size required to meet the size of the sensor and the connection to the main wire-run. These are 25-AWG in many cases, but are not more than 8 to 12 inches in length and are rigidly fastened to the associated structure at more than one point

along the length of the wire.

f. All wiring on the External Tank is 22-AWG or larger except the DFI data-bus wire which is 24-AWG and the one foot long pigtailed on about 70 strain gauges which are 26-AWG.

g. The Solid Rocket Booster uses 26-AWG only as required for sensor pigtailed. Non-shielded wires are 22-AWG or larger. Shielded wires are 24-AWG or larger. The data-bus wire is 24-AWG.

h. The Space Shuttle Main Engine uses 22 AWG or larger except where there are short pigtailed

There is controlled use of Teflon insulated wire on the SSME and the SRB. The use of Teflon inside the ET tanks is still being studied. Kapton covered wire is used on both the External Tank and the Orbiter wherever possible. It is a much stiffer and abrasion resistant material. Cable or harnesses use the Kapton covered wire to act as a sort of "back-bone" for the wire bundles because of its tougher characteristics.

6.3.4.3 Quality Control of Screw Threads

The Panel during its fact-finding sessions reviewed the quality control system on fasteners and their application. It was determined that contractors on the Main Propulsion System survey their manufacturers of flight hardware fasteners and sample incoming lots of fasteners during receiving inspection. They are using either

plug and ring gauges or single element gauging to assure that requirements of the screw thread specifications are being met. It appears that all contractors working with MSFC are using the same controls now as they have in past programs with NASA.

As an example, Thiokol, which manufactures the Solid Rocket Motors, audits or surveys fastener manufacturers each six-month period to assure that inspection records are maintained. The single element gauging of threads meets the requirements of MIL-S-7742 and MIL-S-8879. Thiokol then samples incoming lots during receiving inspection per MIL-S-105 using plug and ring gauges.

On the other hand the External Tank manufacturer, Martin Marietta Corporation at Michoud, does not ordinarily survey their fastener suppliers. They perform receiving inspection per MMC Quality Receiving acceptance plans that specify either 100% inspection or an adequate sampling plan. The single element gauging system is used both in this receiving inspection as well as in laboratory shear and tensile tests.

The contractor for the Main Engine, Rocketdyne, surveys their suppliers yearly and samples each manufacturing lot. The MIL-S-7742A and MIL-S-8879 requirements are on contract. There is thread snap gauge inspection on external threads, as well as visual inspection for uniformity, damage, and so on. This is done on a random basis with

major diameters measured by micrometers. MIL-S-8879 threads are inspected on an optical comparator for root radius. Internal threads are checked for size using thread plug gages and are visually inspected for uniformity, damage, etc. Material tests are performed in the laboratory as well.

No failures attributable to nonconforming screw threads has been found in these or associated contractors as a result of a detailed search of back records.

With regard to the Orbiter it is understood that almost all of the suppliers of threaded fasteners use a single element type gage to control their manufacturing process. The two suppliers that do not use the single element type gage are suppliers of lock nuts which are purposely distorted to provide a locking capability. Threaded fasteners which have material strength levels above 160,000 psi are required to meet military and contractor specifications which contain both functional and macrosection criteria. Criteria include single element as well as functional and special measurements or inspections. Laboratory tests are conducted on sections as well. Fasteners with strength levels below 160,000 psi are required to meet military specifications on thread gaging to assure proper fit and function and to assure that the pitch diameters, root diameters, minor diameters, etc. are within specifications. Optical projection is employed for root radius and minor diameter verification. Since all

Orbiter threaded fasteners are listed in the Orbiter project parts list, other parts can only be procured by the prime contractor or its subcontractors after specific engineering approval.

6.3.5 Addendum

As a result of these reviews, suggestions for future examination have been put forth, these include:

- a. Is there value in co-locating additional S,R&QA personnel within the Shuttle Program Office area reporting directly to the S,R&QA office at Level II. In this way they might provide better day-to-day support to the S,R&QA Panel and other related activities.
- b. The degree of participation by NASA Centers and all NASA prime contractors in the activities of the S,R&QA Panel work.
- c. The experience gained from the landing gear design problem which was exposed during the Orbiter 101 test and checkout work at Palmdale should be provided to all elements of Shuttle.
- d. Determine the background of the landing gear uplock hook failure from the viewpoint of S,R&QA activities at both the contractor and at NASA.
- e. The degree of participation by the S,R&QA personnel in the establishment of test plans and their implementation.

6.4 Additional Mission Safety Assessments

The following material further clarifies material in three areas: (1) ALT mission safety, (2) Requirements Reviews, and (3) Abort and Contingency Plans.

6.4.1 ALT Mission Safety Assessment

The mission safety assessment document is in review at this time. The principal open and closed safety concerns have been discussed for the Shuttle Carrier Aircraft, the Orbiter and the operations phase. The accepted risks for the carrier aircraft, the orbiter, GFE and operations are also shown. This document, JSC 10888, will be updated as required. As an example, the list of concerns and risks for the "Operations" phase are:

1. Open Safety Concerns (Implementation of corrective measures has not been accomplished)
 - a. Lack of hazardous gases vent capabilities in the Orbiter hanger
 - b. Shuttle Carrier Aircraft empennage/aft fuselage buffet with tailcone off.
 - c. Orbiter landing gear deployment during captive flight.
 - d. Incompatibility of the carrier aircraft with hydrazine fuel.
2. Closed Safety Concerns
 - a. Hazardous environment around the carrier aircraft.
 - b. Excessive Orbiter wing loads during mated flights.
3. Operations Accepted Risks

Incompatibility of the carrier aircraft with ammonia, and possible damage to the vertical stabilizer by ejection seat system outer Orbiter panels while mated.

6.4.2 Risk Assessment To Support Requirements Reviews

As in those manned programs preceeding it, the Shuttle program

periodically takes the time to review and clarify the program requirements in light of the most current status and performance estimates for the hardware and software and the constraints of the resources available to meet program objectives. A parallel and independent S,R&QA review is made with respect to every change in requirements put forth for consideration. The degree of this review is not fully known. These safety oriented reviews and assessments are provided so that technical personnel and senior management can consciously consider the impact of such changes before making their decisions. As an example, the flight safety and S,R&QA organizations examined some 340 candidate changes during a recent requirements review covering a period of several months. They determined that about 185 of the candidates had no safety impact, while the impact of the other 155 was identified for management consideration.

6.4.3 Abort And Contingency Planning

To understand the current status of abort and contingency planning efforts and hardware/software implementation the Panel examined the history of this work. This included a review of the decision process to eliminate both the SRB thrust termination and the use of Abort Solid Rocket Motors. Basically these steps were taken because (1) the Abort Solid Rocket Motors added additional mechanical failure modes and large weight penalties, and (2) there were no credible SRB failures during the SRB burn period because of the reliability of such rocket motors.

Further, the Orbiter is to be equipped with two SR-71 aircraft ejection seats for the first four orbital flights (OFT). These have been qualified for and used under conditions exceeding the Shuttle ascent trajectory in terms of mach number, velocity and dynamic pressure. The ejection seats provide an escape capability from the pad to approximately 80,000 feet with these limitations:

1. The seats probably could not be used for an escape off-the-pad with engines running or in the event of an external tank blowup and resultant fireball.
2. They probably would not survive a very rapid breakup of the vehicle in the event of an explosion.
3. They also cannot be used during the last 30 seconds of the 120 seconds of SRB burn or between 80,000 feet and 140,000 feet.

ATTACHMENT 6-1

It is important that senior program management review both the scope and results of safety analyses to reinforce early resolution of risks. Similarly, attention should also be given to the scope and results of technical management audits to assure that such systems as described to the Panel are being applied properly. Two examples are Configuration Management and Material Control.

Response: Safety Analyses are being conducted at the project and program level. Significant "safety concerns" are published separately with rationale for senior program management visibility and review. Critical Items Lists, which include single failure points that could cause loss of vehicle, crew, or mission are to be baselined at the program level, with changes to the baseline approved at program level. In addition, a Mission Assessment Report will be prepared for senior program management visibility and review at the program CDR time period.

Technical surveys and audits are conducted according to schedules established by project and program elements which may cover several technical disciplines or a specific area, e.g., configuration management and material controls. Configuration management is usually covered in conjunction with the annual S,R&QA surveys. Presently, the materials control area is receiving special attention. A survey was conducted in materials in June 1975 of the Orbiter contractor (Rockwell/Space Division). Another survey is planned for the external tank contractor in September 1975, and one for the Solid Rocket Booster contractor (Thiokol) in October 1975.

Contingency analyses especially for aborts, ditching, landing accidents, and range safety should be completed early enough to assure design solution rather than operational work-arounds.

Response:

Aborts

(a) The present abort analysis effort is being concentrated on those cases with the highest probability of occurrence. These are the intact abort cases and include the following:

1. Loss of thrust from one SSME
2. Loss of TVC for one SSME
3. Loss of thrust from one OMS engine
4. Loss of TVC for one axis of SRB

The aborts with a low probability of occurrence are referred to as the contingency abort cases. These cases are being studied, but to a limited degree, in consonance with their low probability of occurrence. Contingency abort cases include the following:

1. Loss of thrust from two or three SSME's
2. Loss of TVC for two or three SSME's
3. Loss of TVC for two or more axes of an SRB
4. Premature Orbiter separation
5. Failure to separate SRB from Orbiter/ET

For certain situations, it is not practical to provide for abort solutions. For these cases, appropriate safety margins and high factors of reliability have been included in the Space Shuttle design to preclude their occurrence. These cases include the following:

1. Major structural failure
2. Complete loss of guidance and/or control
3. Failure to ignite one SRB
4. SSME or SRB hardover
5. Failure to separate Orbiter from ET
6. Premature SRB separation

Ditching

(b) Orbiter ditching tests have been conducted at Langley Research Center. Based on these tests, the Orbiter should be able to land safely on the water, assuming no major structural breakup. Preliminary structural analysis indicates structural breakup will probably not occur for reasonable ditching conditions. There is a possibility of the side egress door jamming during ditching. Alternate ways are being studied to evacuate the Orbiter in case the egress door is jammed during ditching.

Landing Accidents

(c) Analysis is being conducted by JSC and LRC on the energy absorption capability of the Orbiter during landing accidents. The purpose of the analysis is to determine the ability of the crew compartment aft bulkhead to absorb payload loads resulting from landing accidents.

Range Safety

(d) The Range Safety System PDR is scheduled for October 15 through November 7, 1975. This system, baselined over a year ago, has not yet been approved by the Air Force Eastern Test Range (AFETR). In order to resolve the issues raised concerning range safety requirements, a joint NASA-USAF Ad Hoc Committee is being formed to conduct a technical analysis of the hazards of Space Shuttle flights, both developmental and operational, and to trade off hazards against related launch azimuth constraints and vehicle reliability in order to determine a logical approach to assuring public safety. Alternatives will be recommended to NASA management and the Commander, AFETR, for decision.



NATIONAL AERONAUTICS AND SPACE ADMINISTRATION
WASHINGTON, D.C. 20546



REPLY TO
ATTN OF

JAN 1 - 1976

Mr. Howard K. Nason
President, Monsanto Research Corporation
800 N. Lindbergh Boulevard
St. Louis, Missouri 63166

RECEIVED
MRC
20 JAN 1976

Dear Howard:

This is in reply to your letter of December 23, 1975, concerning potential dangers to Space Shuttle missions from nuclear detonations.

The Space Shuttle Program has taken the potential hazards of nuclear activity into account as part of the ongoing program effort. At JSC a Space Radiation Analysis Group is responsible for defining and assessing all potential (pre-flight) and actual (real time) radiation environments which may be encountered on Space Shuttle missions. This effort, as part of the JSC/Rockwell contract NAS-14000, includes a subcontract with Radiation Research Corporation, Ft. Worth, TX, and is being administered by the JSC Radiation Constraints Panel. For Space Shuttle, as in previous programs (Skylab and ASTP), part of this responsibility is the assessment of potential hazards from atmospheric and exoatmospheric nuclear detonations.

The assessment of both immediate and long term hazards to Space Shuttle from nuclear detonations includes:

1. Prompt effect computation (flash blindness, neutrons, x-rays, etc.)
2. Enhanced radiation environment definitions with respect to time, altitude, position, yield, etc.
3. Crew and equipment exposure projections with respect to time and radiation type.
4. Biological effects/crew health evaluation.

The most important aspect of this effort is the refinement of real-time support procedures which will allow for timely data acquisitions, hazard assessment and implementation of related mission rules to insure minimum impact to Space Shuttle crews and mission objectives. For example, if there is advance warning, the line-of-sight situation is avoided, or, if an excessive radiation environment is encountered, the mission will be terminated and re-entry and landing accomplished as soon as possible.

The liaison necessary to support this effort has been established through the Office of DOD and Interagency Affairs. The Office of International Affairs also plays a part in advising appropriate countries of NASA flight plans for manned missions to help minimize the likelihood of an inadvertent encounter with a nuclear event,

As you can understand, there are many aspects to this kind of an effort. In connection with the planned Aerospace Safety Advisory Panel meeting at JSC next month, you might wish to talk to Rod Rose who could give you further details,

Sincerely,

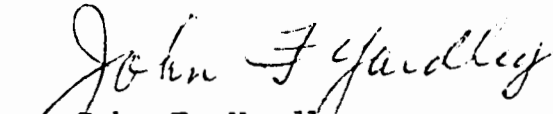
John F. Yardley
Associate Administrator
for Space Flight

cc:
AD/Dr. George Low
APA/Carl Praktish
Gen. Warren D. Johnson, USAF

TABLE 6-1

IMPLEMENTATION STATUS - LESSONS LEARNED AS
APPLIED TO THE EXTERNAL TANK
(Mid-1975)

DOCUMENTS	TOTAL NO. LESSONS APPLICABLE	ENGINEERING		PRODUCT ASSURANCE		PRODUCTION OPERATIONS		MATERIAL		CONTRACTS		TOTAL IMPLEMENTED
		APL'D*	IMPL.*	APPL'D	IMPL	APPL'D	IMPL	APPL'D	IMPL	APPL'D	IMPL	
JSC-09096	20	18	7	4	4	1	0	2	2	1	1	9
MSFC-SAT-SL-2-74	14	14	11	3	3	0	0	1	1	1	1	11
Lessons Learned - KSC	13	10	5	3	3	1	1	1	1	0	0	7
NASA HO-SL-3-74	14	12	11	6	6	4	3	0	0	0	0	10
S-II Stage	154	144	117	7	7	12	9	2	2	1	1	129
Skylab	37	31	3	5	5	4	4	1	1	1	1	10
NASA TM X-64574	29	2	1	22	9	9	5	0	0	0	0	12
MSC-00134	127	87	26	16	16	37	17	0	0	2	2	39
MSCM-8080	68	59	20	12	12	10	7	2	2	0	0	27
TOTALS	476	378	201	78	65	78	46	9	9	6	6	254

179

NOTES-In addition to the above the following additional items have been identified for further review:
 MSCM 8080 7 lessons
 All other documents 67 lessons

*APPL'D = Applied
 IMPL. = Implemented

TABLE 6-2

SELECTED OPEN SAFETY CONCERNS

1. SSME Heat Exchanger Leakage
2. Ice From ET, Impact On Orbiter TPS
3. Post Separation Impact of Orbiter By ET
4. Use of SRB Nozzle Extension Separation Ordnance During OFT
5. SRB Ignition Overpressure On Space Shuttle During Lift-Off
6. Shuttle Potential Collision With The Tower On Lift-Off
7. Fire Potential In Orbiter Aft Fuselage On Launch Pad
8. Pre-Entry Thermal Conditioning Requirement For On-Orbit Contingency Aborts

CLOSED SAFETY CONCERNS

1. Access To SRB At Pad For Ordnance Checks
2. Impingment Of SRB Separation Rocket Motor Plume On Orbiter
3. Shuttle Vehicle POGO Suppression
4. Propellant Mixing At ET/Orbiter Umbilical During Separation
5. ET Venting Of Gaseous Hydrogen In-Flight
6. Jamming Of Payload Bay Doors In The Open Position
7. Deletion Of Drag Chute Subsystem
8. Smoke Sensor Provisions In The Orbiter Crew Cabin
9. Verification Of Crew Module Side And Airlock Hatch Pressure Integrity
10. OMS Pod And Wing Vent Mechanisms
11. Possible Forward Fuselage And Crew Module Collapse
12. Secondary Emergency Escape Provision
13. Orbiter Nose And Main Landing Gear Deployment
14. Venting Of LOX Tank Into ET Nose Cap
15. SRB Separation System Timing
16. Shuttle Carrier Aircraft/Orbiter Release Capability during ALT

ACCEPTED RISKS

1. On-Orbit Rescue During Early Orbital Flights
2. Manual Guidance Capability During Ascent
3. Emergency Drain System Provisions For ET
4. Smoke Sensor Provisions In The Orbiter Crew Cabin for ALT
5. Single Elevon Hydraulic Actuator
6. Bird Impact With Orbiter Windshield
7. Thermal Windshield Panes

TABLE 6-3

LEVEL II S,R&QA PRODUCTS (SELECTED)

1. ALT Mission Safety Assessment
2. Space Shuttle Safety Concerns
3. Space Transportation System Payload Safety Guidelines
4. Vehicle/Ground Systems Integrated Hazard Analysis
5. Main Propulsion Test Safety Plan
6. Main Propulsion Test Integrated Hazard Analysis
7. FMEA/CIL Status
8. Criteria And Standards Implementation Plans
9. SSME Heat Exchanger Pedigree Plan
10. Acceptance Data Package
11. Joint Surveys of NASA/Contractor Operations
12. Non-Destructive Evaluation
13. NSTL Quality Assurance Plan
14. Space Shuttle Personnel Motivation
15. Shuttle Orbiter Carrier Aircraft Service Bulletins
16. Shuttle/Spacelab Interface: Hazard Analysis and Payload Bay Fire Detection and Suppression
17. Space Shuttle SR&QA Plan
18. Interface Assurance Plans
19. ALT Safety Plan
20. OFT Safety Plan

FIGURE 6-1
SOLID ROCKET BOOSTER
FRACTURE CONTROL BOARD ORGANIZATION

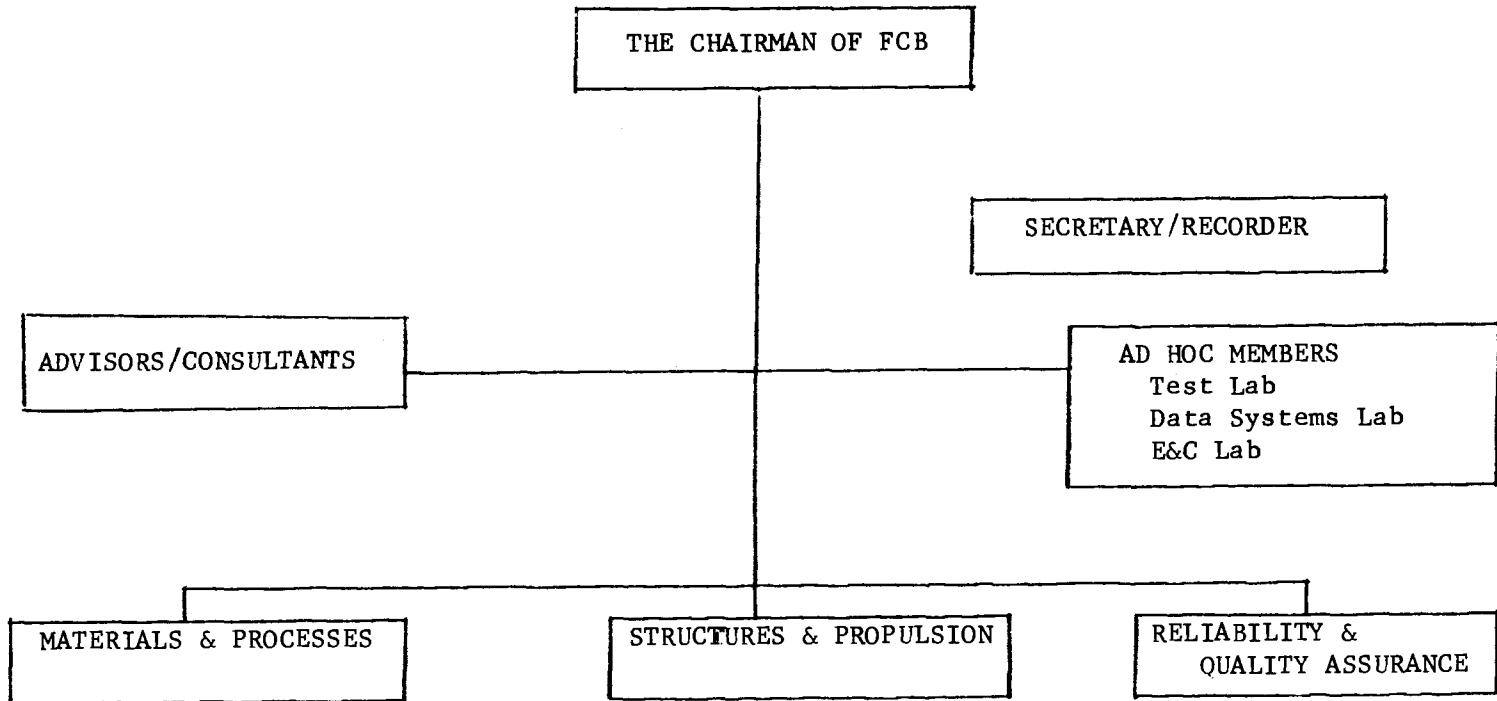
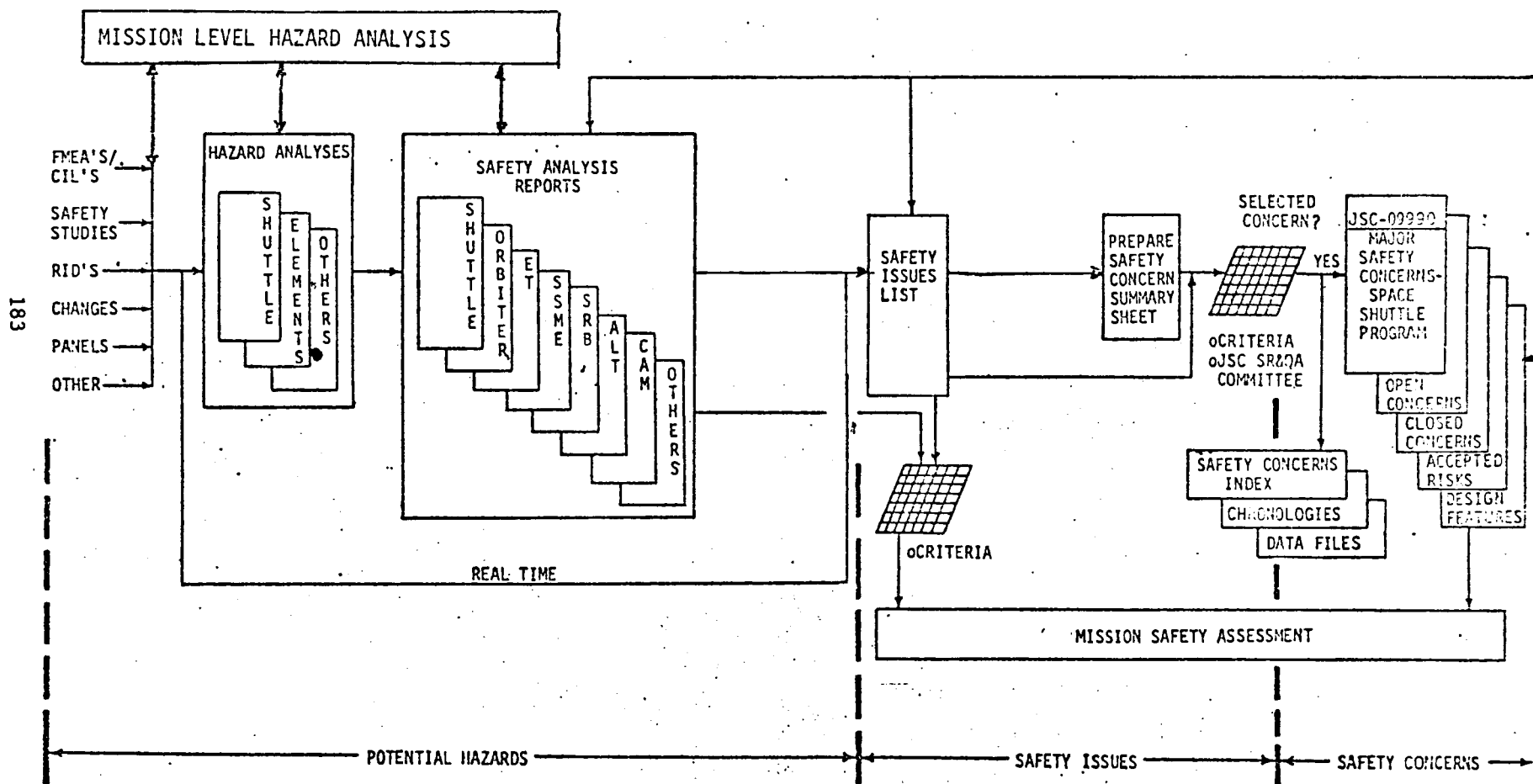

FIGURE 6-2

RISK ASSESSMENT PROCESS



183

7.0 GROUND TEST PROGRAM/GROUND SUPPORT EQUIPMENT

7.1 Introduction

While this section of the report covers both the Shuttle major ground test program and Shuttle ground support equipment the task team gave priority to the test program. The major elements and major inter-element systems have reached that maturity of design and fabrication where major ground test programs are being initiated. These major ground test programs are conducted to prove the designs do meet performance requirements prior to their use in actual flight tests.

These ground test programs support both the upcoming Approach and Landing Tests (ALT) and the later Orbital Flight Tests (OFT). Therefore, the Panel's objectives are to assess the degree of confidence one can have in the program meeting those goals which are dependent upon ground test results, and define those areas of concern and proposed actions to resolve them.

As for ground support equipment the Panel has been reviewing the plans for acquisition, testing and use of such equipment, in order to define those ALT areas which should receive priority attention.

The Shuttle Program Office response to the Panel's previous Annual Report is included as Attachment 7-1. This covers two items: (1) assurance that the system for defining and implementing requirements will give appropriate attention to safety and (2) assurance

that planning is sufficient for ground testing to maximize confidence in safe development flights.

7.2 Shuttle Master Verification Plan (MVP)

The Shuttle MVP establishes the requirements and plans for verification of the Shuttle system for operational use, and provides the mechanism for program visibility and control. This plan consists of eleven volumes covering the following areas:

Volume I	General Approach and Guidelines
Volume II	Combined Element Verification Plan
Volume III thru VI	Element Verification Plans (Orbiter, SRB, ET, SSME)
Volume VII	Payload and Payload Carrier Verification (This is contained in Volume XIV, JSC 07700)
Volume VIII	Launch and Landing Site Verification Plan
Volume IX	Computer Systems and Software Verification Plan
Volume X	Master Flight Test Assignments Document
Volume XI	Shuttle Orbital Flight Test Requirements

The detail of this documentation and the planning that it represents is to assure the most effective utilization of program resources. The methods of verification include analysis and / or test. Thus decisions on the amount of hardware in a test program, the depth of the test program, the degree of element assembly at which tests are conducted are based on such factors as the sophistication of the design analysis,

the design maturity at the time of tests or analyses, the risk associated with degree of knowledge, the complexity of the test articles and the test program.

Phases of the verification program have been divided into (1) development, (2) certification, (3) element/system verification, (4) acceptance and checkout, and (5) ground system verification. This is then followed by the "proof of the pudding" in flight demonstration tests of the mature systems. The flight demonstration tests are in two phases: (1) the approach and landing test project dealing with the Orbiter and (2) the orbital flight test program using the entire Shuttle system of ground and flight equipments. After these phases the total Shuttle system is available for operations.

The following definitions are taken from the Master Verification Plan because they are very helpful in understanding the test plans.

a. Development testing is the program which verifies the design approach.

b. Certification testing is the program of qualification tests, major ground tests, and similar tests and analyses required to determine that the design meets the specified requirements. Major ground tests involve a combination of system elements, complex facilities, and large or expensive hardware segments. Qualification tests can and usually are conducted on components and assemblies within a single element, such as the external tank or the Orbiter.

c. Verification testing is the program to prove that the Shuttle system meets all designs, performance, and safety requirements.

d. Acceptance testing is the program that demonstrates that the actual part, component, subsystem, or system used in a Shuttle vehicle is capable of meeting performance requirements in such documents as the Contract End Item Specifications and so on.

e. Checkout testing is the program that verifies that the hardware/software for a specific mission will function within the prescribed flight limits both at subsystem and integrated vehicle levels.

f. Flight demonstration is the program that verifies the performance of the flight vehicles under predetermined flight conditions.

7.3 Review of the Test Program

The Panel in assessing the confidence level provided by the Shuttle test program focused on two areas: (1) the certification program for the first captive flight of Orbiter 101 mated with the 747 carrier aircraft and the certification program for the first free flight of Orbiter 101 in the ALT project, and (2) the certification program for the first manned orbital flight with an "all-up" Shuttle system.

Although the Space Shuttle ground tests are based to some extent on experience gained from such programs as Apollo, Skylab and ASTP and the unmanned programs, the uniqueness and resource constraints of this program levy different requirements and expectations. Therefore, areas of interest reviewed by the Panel included the following:

a. The test organizations at NASA Centers and their contractors with regard to responsibility and authority in the Shuttle program organization, their personnel numbers and skills, and the modes of management and communication.

b. Those tests considered mandatory prior to first flights and the rationale for this determination.

c. The logic behind decisions on additions, deletions, deferrals of the test requirements and the impact on hazards and risk acceptance.

d. The contingency plans to cope with "surprises" which usually occur during any test program.

e. Specific attention being paid by the program to critical items including those that have no redundancy, e.g., wing elevon actuators, thrust vector control actuators.

f. The system for assuring that the test requirements and procedures as well as hardware configuration control for a specific piece of hardware or software demonstrate the flight worthiness of that hardware or software.

g. The degree to which the test program and individual tests add up to an integrated test program and a reasonable basis for confidence in decisions on the flight worthiness of the Shuttle.

h. Retest plans that assure adequate demonstration of vehicle integrity after replacements, modifications, repair, etc.

i. The system to assess the degree to which model testing, such as 1/4-scale model vibration and wind tunnel testing, will parallel the actual flight experience and therefore the difference that will have to be

considered in defining a safe flight test program.

j. Specific test situations such as:

(1) The ground rules for testing hardware so that it will see the full mission cycle environment rather than just its operating cycle environment.

(2) The rationale for using the structural ground test program as the basis for certifying the Orbiter 101 flight vehicle.

(3) The rigor of the testing to assure payload doors can be closed in orbit.

(4) The ground test program to determine control capabilities if a contingency situation develops where one or more APU's fail to operate.

(5) The program to accomplish some form of verification program for critical mechanisms to be sure that they can meet the conditions presented in long space soaks, long periods between checkout and use, and long periods of inactivity on the ground. Such critical mechanisms include the many door-control units on the Orbiter, and the flight control hardware.

(6) The rigor of the landing gear deployment test program to assure deployment during actual flights.

(7) Planned use of test teams and ground support equipment at factory, NASA Center, and specifically at KSC to assure that there is a maximum accumulation of experience and safe test operation.

7.4 Structural Proof Tests, Orbiter 101

Orbiter proof tests are to provide confidence in early phases of the flight test program by verifying integrity and rigging of control systems and selected doors. These tests assure that (1) control surface and door mechanisms and the associated structure have the strength and stiffness to withstand limit loads (i.e., maximum load expected during mission operation) without loss of operational capability, and (2) the hydraulic subsystem will provide the necessary stiffness to these surfaces to withstand aerodynamic flutter. The loads are those expected on the Orbiter 102 during an orbital mission. The test article is a flight vehicle except for the following items which would not be installed at that time: tailcone; thermal seals on the landing gear doors and rudder speed brake; elevon surface seals and TPS; crew seats and rails; pyrotechnic devices; and the use of simulated SSME's.

The testing will be performed after manufacturing checkout and before the ground vibration tests at the RI Palmdale assembly facility. The Orbiter 101 will be certified by analysis, and the vehicle will be placarded to 75% of limit load for all critical horizontal flight conditions. This does not include the thermal stress loads of Orbiter 102. The flight placards are being developed using ALT weights and configurations to derive ALT external loading and internal loading indicators to compare with the Orbiter 101 detail design and analysis. Because of the complexity and inherent costs required to separate thermal effects

from Orbiter 101 stress analysis the certification analysis will assume that thermal effects are present thus resulting in an additional structural margin.

The proof tests on the control surfaces of the 101 will develop design limit hinge moments with the actuation systems operating and the surfaces positioned at angles of deflection at which limit loads will occur. The landing gear doors will be proof loaded. The landing gear itself will be certified by component testing. The crew module will be pressure proof loaded to 17.7 psig which is 110% of design limit pressure. Modal surveys at frequencies of body bending and torsion, including torsion modes of the wing and fin, will be conducted on the Orbiter 101 after factory checkout to substantiate and update the dynamic math model by correlating analytical predictions with the measured test data. In addition there will be a calibration of the wind root strain gages during free flight to further substantiate the analyses. This will be done by comparing predicted conditions with flight data so that inflight loads will be verified before further explorations of the Orbiter flight boundaries.

To provide a baseline for evaluating the adequacy of this test approach, the related information from military and commercial wide-body test programs is summarized here:

a. The L-1011 underwent a test program that included development component testing, proof loading to the limit load of control surfaces

and landing gear components, pressure proof testing of cabin to 60% of limit pressure. The completed stress analyses was accomplished prior to flight test. No primary structure proof loading or static test article loading was considered necessary. The vehicle was placarded to 80% of the limit load. Subsequent testing included a full airframe static and fatigue test.

b. The DC-10 designs underwent proof loading to limit load and this data was extrapolated to verify the analyses prior to first flight. In addition, the controls of the flight test aircraft were proof loaded and ground vibration tests were conducted prior to flight tests. No placards were imposed on the flight test.

c. The Boeing 747 experience prior to first flight is consistent with the DC-10. Full-scale static and fatigue articles were subsequently performed.

The primary structure will be fully certified prior to first vertical flight (OFT). The program calls for continuing testing in conjunction with analyses of the governing flight conditions. Thus, the static test article will be subjected to ultimate loads. Vibroacoustic tests will be completed on the aft fuselage test article. Vertical vibration tests and static firing of the main propulsion test article also remain to be done along with wind tunnel model testing. Component tests on such items as the window, side hatch, airlock seals and static and dynamic seals continues at this time. The Orbiter will not be placarded for vertical flight, but trajectory tailoring and adaptive flight control

will keep the loads well within prescribed limits.

7.5 Structural Test Article (Orbiter)

The Structural Test Article (STA) is of a production-type Orbiter in two sections, the airframe assembly and the crew module section, which will be subjected to static load testing in a special test series conducted by the Lockheed Company. During this major structural test, all major parts of the vehicle will be subjected to limit, fatigue, and ultimate loads to induce design level stresses and prove that all parts are capable of taking the expected loads safely. The airframe for STA uses substitute hardware for the nose and main landing gear, control surface actuators, crew module, OMS/RCS pods, and thermal panes. The crew module for STA uses substitute hardware for the windows and airlock tunnel.

Milestones for the STA program are as follows:

- a. Delivery of the airframe to Palmdale test site during the first quarter of 1977.
- b. Delivery of the crew module during the third quarter of 1977 to RI/Space Division.
- c. Completion of the crew module tests in the Fall of 1978.
- d. Completion of the airframe tests with a simulated crew module in the first quarter of 1979.

The four series of tests on the STA will cover influence coefficients such as modulus of elasticity, the limit loads, the fatigue loads and the ultimate load.

7.6 Payload Bay Doors

The following questions were asked during the Panel's examination of the payload bay door system: What testing is planned to assure payload bay doors can be closed in flight? What requirements are in the baseline for Extra Vehicular Activity (EVA) capability to overcome a problem which prevents door closure? What is the status of the development of this EVA capability? Responses to these questions are summarized below:

a. The planned test program provides for subsystem tests on latches and drive mechanisms; development tests on structural materials, lubrication, and mechanism latches; qualification tests simulating zero "g" and one "g" operations as well as on-orbit distortions with a 15-foot section of payload bay door and mating fixture. Details for this test are still being worked out.

b. The Payload bay door system is being designed so that for manual operation by a crewman in EVA in case there is an on-orbit problem with the door. Certain payload configurations and postulated failure modes will preclude access to the mechanisms. Thus JSC and RI/Space Division are currently assessing such challenges as the methods of ensuring that the doors can always be driven to an "open" position and the allowable number of latches "out" and still have a safe return. EVA routes and working envelopes required for a manual operation of the doors are under evaluation.

c. Airlock, EVA hardware, and EVA hardware servicing and recharge are now baselined. EVA provisions, such as translation aids, work stations, etc., have been developed and will be implemented in the near future. Handrails already designed for the remote manipulator system will provide additional EVA flexibility. The airlock locations and configurations that form a part of the total system have also been baselined at this time.

7.7 Ground Vibration Tests (GVT)

There are a number of ground vibration tests that have been discussed by the Panel: (1) Orbiter GVT, (2) Mated Orbiter/747, (3) Mated Vertical GVT including all flight elements of the Shuttle system. The overall ground vibration test program uses the building-block approach with tests progressing from one-fourth-scale models to the full-scale Shuttle system. Thus the initial verification testing of math models and analytical techniques will use the 1/4 models constructed of the same materials as the flight articles and made to the production drawings. These 1/4-scale models of the Orbiter, ET, SRB's should be ready before the end of 1976. After completion of the development testing phase at Rockwell they will be transferred to JSC for payload integration studies and operational support of the program.

7.7.1 Orbiter Horizontal Ground Vibration Test (HGVT)

The objectives of this test program are to determine the Orbiter modal characteristics for two support conditions: (1) Orbiter free

flight called a "soft" vibration test (Figure 7-1), and (2) Orbiter mated-type called a "rigid" vibration test (Figure 7-2). The soft or free-flight vibration test will also define the flight control frequency response characteristics relating to the deflection and slope at control system sensors for known input at the aerodynamic control surfaces. These tests are conducted on the Orbiter 101 or ALT Vehicle. These vibration tests are conducted following the structural mechanical proof load tests and are all conducted at the Palmdale facility. Rigid mount tests are to begin in late July 1976 and the soft mount tests are to begin in mid-August after completion of the rigid tests. Figure 7-3 shows the Palmdale checkout flow which includes these vibration tests.

7.7.2 Mated Orbiter/747 Ground Vibration Tests

The purpose of this type of test would be to assess and verify the adequacy of structural dynamic modeling and checkout structural response instrumentation. The need for such a test program is being examined by Rockwell and then recommendations will be brought to the Orbiter and Shuttle management for a decision.

7.7.3 Mated Vertical Ground Vibration Test Program (MGVT)

This test at MSFC is the culmination of the individual and scale model testing. As described to the Panel by the ground test subsystem managers there will be two major integrated vibration test phases:

- (1) a model test of the Orbiter/ET assembly on a soft suspension system

and (2) a modal test including the Orbiter, ET, SRB's to investigate conditions at lift-off, high-Q, and burnout. Initially, rigid-body modes will be determined to insure that the natural frequencies of the "soft" suspension system can be adequately accommodated. During these tests special precautions will be taken to prevent damage of any kind to the Orbiter and the ET since they will be refurbished and used for flight hardware. The SRB's will not be used as flight hardware.

7.8 Flight Control Hydraulic Laboratory (FCHL)

The objectives of tests conducted on the FCHL include: (1) verification of the hydraulic system, (2) integrated tests with the avionics development laboratory and hybrid computer for verification of end-to-end flight control system, (3) verification of the structural adequacy of the various control surface actuator mountings, (4) verification of the flight controls operations during real-time simulated mission segments, and (5) development of operational procedures to maintain a working hydraulic system. The test article as used in the FCHL is referred to as the Orbiter "iron bird", see Figure 7-4. It uses a qualifiable hydraulic system with simulated main engines, simulated aersurfaces and actuator mounts, but without landing gears. This program has been in progress since late in 1975 and will continue through early 1978. Current work will support the ALT project and later test work will support the first orbital manned test flights.

7.9 Crew Escape System Sled Test

The objectives of this test are to verify the capability and limits of the crew escape system for ALT and OFT including flare, landing, high-Q and High-G conditions. Current plans include one static and three dynamic tests to be conducted at the Holloman Air Force Base test track. Part of the work will validate the 6-degree-of-freedom computer analysis for adverse conditions which cannot be tested. An idea of the test itself and the items to be examined are shown in Figure 7-5.

7.10 Other Major Tests

A number of tests are covered under more specific chapter of this report, e.g., the Main Propulsion Test program. Others have not been examined to any degree by the Panel, e.g., vibroacoustic testing on the Orbiter aft fuselage. In addition to the so-called "major tests" the Panel expects to review the development and testing applied to some of the more critical hardware such as the Auxiliary Power Units, the fuel cells, thrust vector control and elevon actuators and others as deemed necessary.

7.11 Ground Support Equipment (GSE)

GSE is classified on the Shuttle program in accordance with the following functional groupings:

- a. The servicing support equipment which supplies fluids and power to the flight hardware and associated GSE. This class includes equipment for supplying pressurization, purging, transferring fluids, etc.

b. Checkout and Test equipment which is used in all test and checkout operations. This class includes equipment that monitors, evaluates and stimulates hardware.

c. Handling and Transportation equipment which is required for the movement and support of flight hardware, including slings, stands, etc.

d. Auxiliary equipment which aligns, protects and calibrates flight hardware.

e. Umbilicals which are those items interfacing directly with the Shuttle elements to transfer electrical power, electronic signals, and fluids to and from the flight vehicle systems.

This area has been given lower priority by the Panel only because of the press of other Panel efforts. To some degree the Panel is in the process of scoping the task and defining the most effective approach to a continuing review of this area. The Panel began by reviewing the adequacy of management efforts to assure safe, cost-effective means of processing the Shuttle during all of its test and operational missions. The Panel has also reviewed the requirements and constraints placed on meeting the turnaround time and maintenance requirements, as well as the arrangements for alternate-field landings by the Orbiter.

Indicative of the examination the Panel expects to follow are the following:

a. How does KSC monitor the contractors for design and acquisition of ground support equipment that is to be used at KSC? What part does

JSC and MSFC play in the design, acquisition and use of GSE?

b. What are the critical elements within the GSE system?

c. What are the constraints on GSE development and procurement from the point of view of resources and schedule, and what are their impacts on the GSE program?

d. What are the plans for GSE to support the ALT project beginning with the preparation for the first flight in early 1977?

7.11.2 GSE Design Review Board

The group was established in early 1974 after the Orbiter 101 Preliminary Design Review conducted in February 1974. This Board is chaired by JSC personnel from the Orbiter Manufacturing and Test Office and from the Test Division of the Program Operations Office. Other members of the GSE Board are from RI/^Space Division, the Orbiter contractors, KSC, MSFC with other members added as required from the three NASA Centers. Meetings of this Board are conducted monthly to assure that the designs are evaluated through a system of reviews similar to that for major elements of the Shuttle system (PRR's, PDR's, CDR's) before approval and authority to proceed are given. An example of this activity is the GSE Board Review of April 7, 1976 in which 37 models of GSE were reviewed. The results were that 28 models were approved (7 for PRR, 1 for PRR/PDR, 9 for PDR, and 1 for PDR/CDR, and 10 for CDR), and two models were deleted or disapproved. The remaining models of GSE were deferred to the May Board for disposition. In addition, during this April meeting the Board handled fourteen (14) action items from previous meetings. In these

activities all personnel have an opportunity to write Review Item Dispositions (RID) where they feel there is an inadequacy. This is the same as the system used on the various elements of the Shuttle system.

7.11.2 GSE Design Review Status

Program studies are underway to assure: (1) common hypergolic servicing equipment to the optimum extent, (2) appropriate hydraulic servicing and test capability at KSC, (3) safe Solid Rocket Motor handling operations. The greatest numbers of GSE design reviews will occur in 1976. As expected, the evolving maturity of requirements has resulted in a slight increase of GSE models since July 1975. The planning for on-line maintenance and turnaround equipment and facilities for KSC is progressing satisfactorily. Maintenance planning for off-line Line Replaceable Units (LRU) has been postponed for the present.

7.12 Addendum

An updated summary showing the test, configuration, purpose and expected date of the test is shown in Table 7-1

ATTACHMENT 7-1

The program in assuring the cost effectiveness of its requirements for ground support equipment needs to assure safety receives appropriate attention.

Response: One method of minimizing GSE program cost has been to institute an aggressive effort to assure that the maximum number of GSE end items is common to development test programs, the ALT program, etc., prior to OFT useage. Hazard analyses are being conducted on this equipment to assure adequate attention is being given to safety. Additionally, the Space Shuttle GSE design requirements have been reduced from the reliability level required to meet launch windows (Apollo) to a "fail-safe" requirement. This provides GSE which can sustain failure without loss of vehicle systems or loss of personnel capbability.

ATTACHMENT 7-1 (Continued)

The program is in the period of defining the detailed requirements and plans for major development and flight testing. Plans for ground testing appear adequate. Safety-related testing should be monitored to insure it is carried through as planned. The interactions between the Orbiter, External Tank, and Solid Rocket Booster, including separation dynamics, are complex. Analyses based on ground testing should be thorough enough to maximize confidence in safe development flights.

Response: As noted by the ASAP, separation dynamics is a subject of continuous analysis backed up by ground test program. Wind tunnel tests of the ALT configuration (Orbiter/747) and the orbital configuration (Orbiter, ET, SRB) are being conducted to determine separation load dynamics. Actual ground tests of the separation hardware under various load conditions are planned. For ALT, safe separation loads using load cells in the actual flight separation system are being developed. Trajectory analysis of the ALT fly away and the SRB's and ET separations are being continually updated to investigate no recontact and safe separation. For ALT, approximately 4,000 computer runs of different test conditions were investigated in special McDonnell Douglas studies to assure safe operational separation margins. These types of analysis and testing will continue with the specific objective of assessing confidence in safe development flights.

SPACE SHUTTLE PROGRAM

GROUND TEST (1 OF 2)

<u>TEST</u>	<u>CONFIGURATION</u>	<u>PURPOSE</u>	<u>TEST START</u>
● GROUND VIBRATION TEST			
- HORIZONTAL SOFT MOUNT	OV-101 IN THE PRE-ALT CONFIGURATION	DETERMINE THE ORBITER FREE-FREE MODAL FREQ, MODE SHAPES AND DAMPING CHARACTERISTICS	AUG 76
- HORIZONTAL HARD MOUNT	OV-101 IN THE PRE-ALT CONFIGURATION	DETERMINE THE ORBITER MODAL FREQ, MODE SHAPES AND DAMPING CHARACTERISTICS - MOUNTED ON ET STRUTS	AUG 76
- 1/4 SCALE MODEL	1/4 SCALE REPLICA MODEL FOR ORB/ET/ AND SRB	MEASURE TRANSFER FUNCTIONS, AMPLITUDE - FREQ, MODAL DAMPING CHARACTERISTICS AND RIGID BODY MODES	NOV 76
- FULL SCALE MATED	ET/SRB/OV-101	VERIFY THE COUPLED DYNAMIC MATH MODEL OF THE MATED SHUTTLE CONFIGURATION	MAR 78
● ECLSS			
	BOILERPLATE TEST ARTICLE, COMPLETE ECLSS, PARTIAL AVIONICS, CREW EQUIPMENT	VERIFY ECLSS INTEGRATED OPS & PERFORM MANRATING OF ECLSS FOR FVF	MAR 77
● STRUCTURAL STATIC/FATIGUE (ORBITER)			
	AIRFRAME STRUCTURE INCLUDING ALL PRIMARY AND SELECTED SECONDARY STRUCTURE, GENERALLY, NO SYSTEMS	VERIFY STRUCTURAL INTEGRITY FOR: LIMIT & ULTIMATE LOADS AND 100 MISSION LIFE X SCATTER FACTOR OF 4	AUG 77
● STRUCTURAL TEST ARTICLE (ET)			
	LO ₂ TANK, LH ₂ TANK AND INTER TANK	VERIFY THE STRENGTH INTEGRITY OF THE PRIMARY LOAD CARRYING STRUCTURE	OCT 77

TABLE 7-1 (CONCLUDED)

SPACE SHUTTLE PROGRAM

GROUND TEST (2 OF 2)

LG
MAY 76

205

<u>TEST</u>	<u>CONFIGURATION</u>	<u>PURPOSE</u>	<u>TESTS START</u>
● MPTA	3 MAIN ENGINES + FLIGHT WEIGHT EXTERNAL TANK + FLIGHT WEIGHT AFT FUSELAGE, INTERFACE SECTION AND A BOILERPLATE MID/FWD FUSELAGE TRUSS STRUCTURE	VERIFY MPS PERFORMANCE AND COMPATIBILITY WITH INTERFACING ELEMENTS & SUBSYSTEM	DEC 77
● STATIC STRUCTURAL TEST (SRB)	SRB SHORT STACK CONFIGURATION, STRUCTURALLY FLIGHT TYPE VEHICLE WITH FOUR CENTER MOTOR SEGMENTS ELIMINATED	VERIFY STRUCTURAL INTEGRITY FOR CRITICAL DESIGN LIMIT & ULTIMATE LOADS AND THE NORMAL SERVICE LIFE	NOV 77
● FWD RCS STATIC FIRINGS	SHALL CONSIST OF STRUCTURE AND COMPONENTS FUNCTIONALLY CON- FIGURED TO REPRESENT THE FLIGHT ARTICLE	DEMONSTRATE THE RCS PERFORMANCE AND COMPATIBILITY WITH INTER- FACING ELEMENTS AND SUBSYSTEMS	NOV 77
● OMS/RCS STATIC FIRINGS	SHALL CONSIST OF FLIGHT WEIGHT PRIMARY & SECONDARY STRUCTURE, FLIGHT WEIGHT QUALIFIABLE COMPONENTS FUNCTIONALLY CONFIGURED TO REPRESENT THE FLIGHT ARTICLE	DEMONSTRATE OMS/RCS PERFORMANCE AND COMPATIBILITY WITH INTER- FACING ELEMENTS AND SUBSYSTEMS	JAN 78
● VIBRO ACOUSTIC AFT FUS. <div style="border: 1px solid black; padding: 5px; width: fit-content; margin-top: 5px;"> NOW DELETED. ACOUSTIC DATA WILL BE OBTAINED IN MPTA </div>	COMPLETE AFT FUSELAGE STRUCTURE, PARTIAL MIDBODY FUSELAGE AND A CLOSEOUT BULKHEAD, 100% IN- STALLATION OF TPS & TCS	PROVIDE DATA: ● TO ESTIMATE THE STRUCTURAL INTEGRITY ● TO VERIFY VIBRATION ENVIRON- MENTAL CRITERIA ● TO VERIFY INTERNAL ACOUSTIC CRITERIA	SEP 78 (ORIGINAL PLAN)

FIGURE 7-1

HORIZONTAL GROUND VIBRATION TEST
TEST ARTICLE DESCRIPTION

ORBITER 101 - SOFT VIBRATION

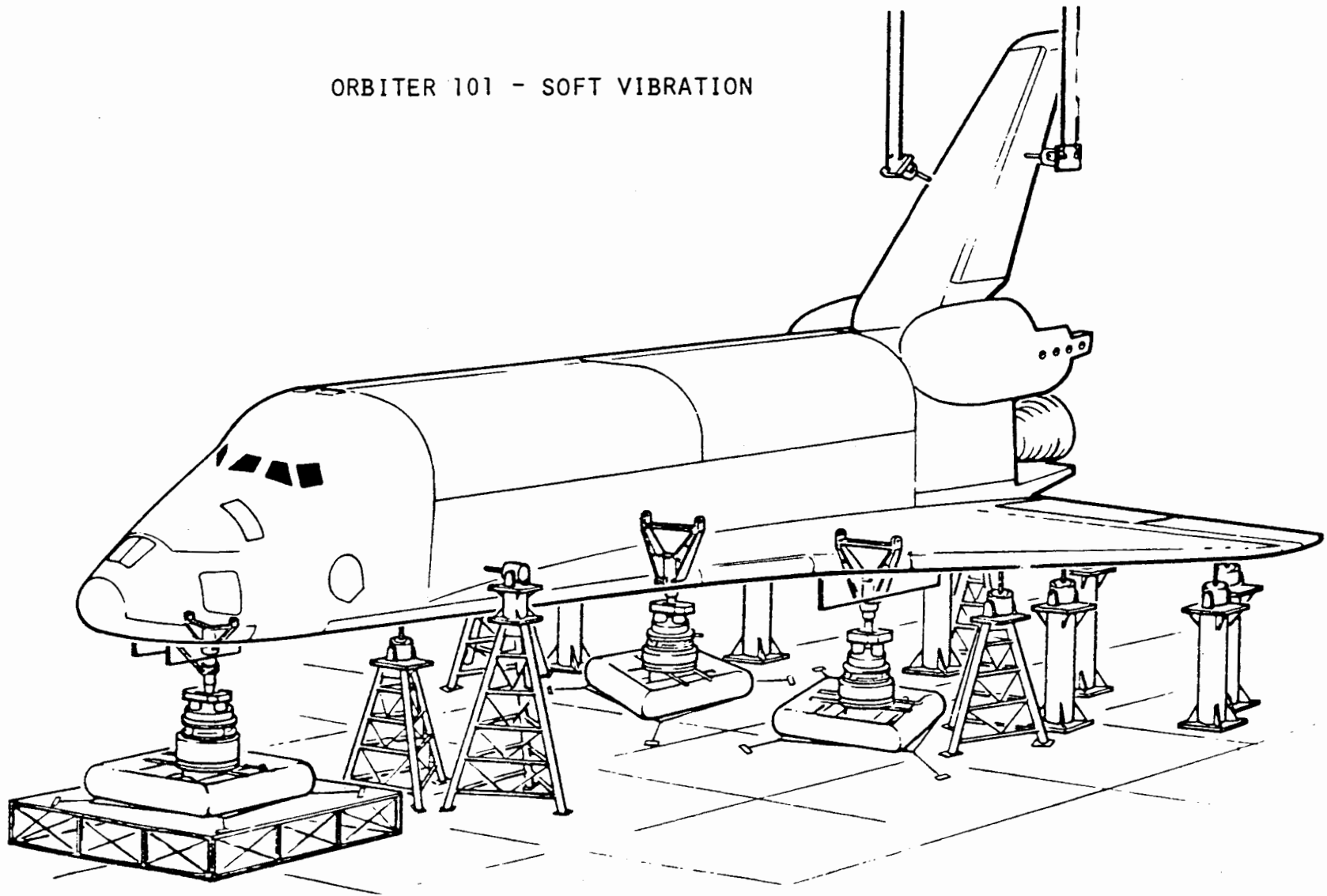

FIGURE 7-2

HORIZONTAL GROUND VIBRATION TEST
TEST ARTICLE DESCRIPTION

ORBITER 101 - RIGID VIBRATION

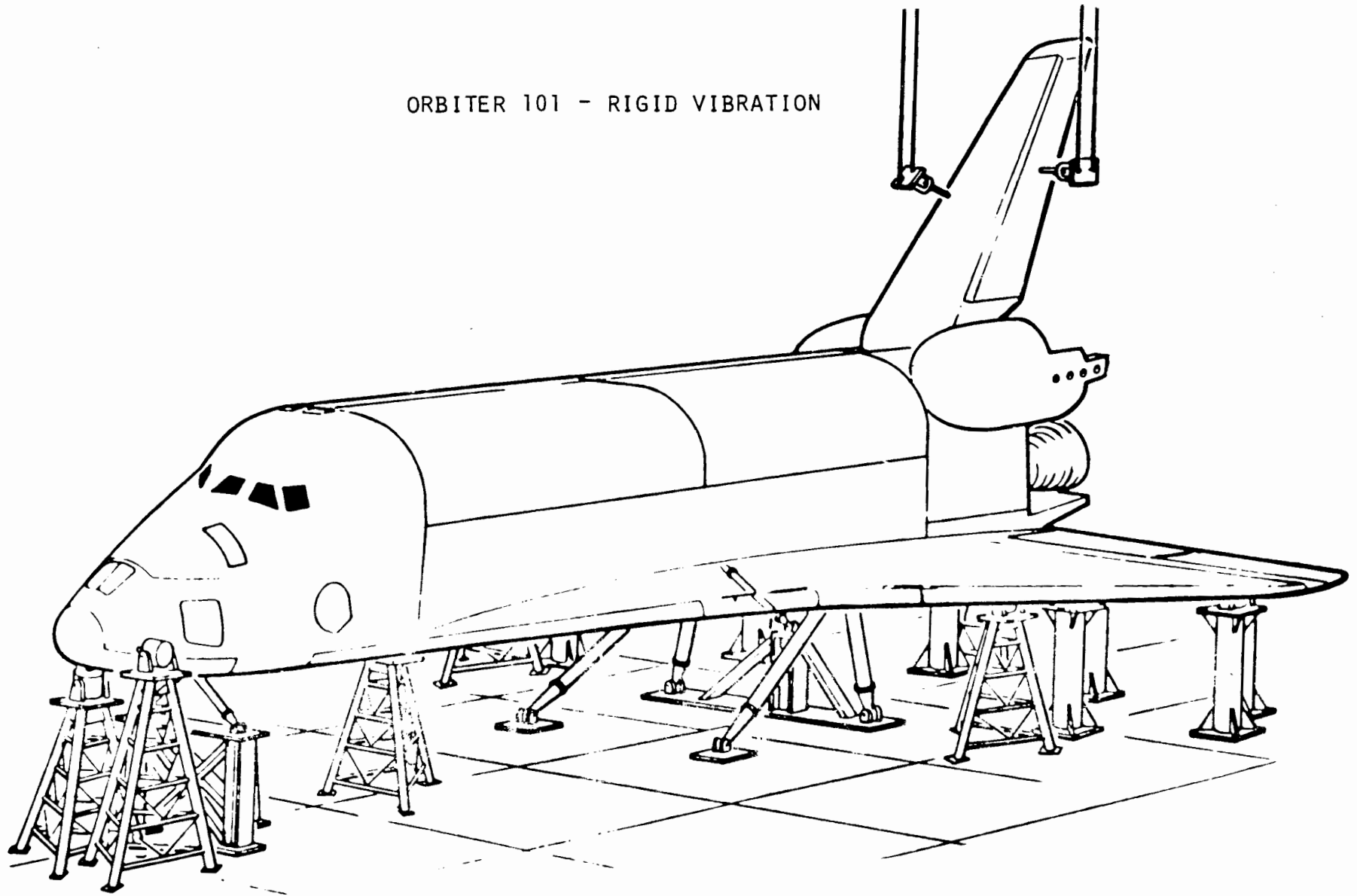

FIGURE 7-3

PALMDALE CHECKOUT FLOW AND CRITICAL PATH

208

